



620 Magnolia Avenue  
Suite B  
Ontario, CA 91762  
(909) 923-1973

## WIRING SCHEMATICS

# **CLUB CAR PRECEDENT w/AUTOMATIC PARKING BRAKE**

REVISION: F  
DATE: 9-20-18

NOTICE: This drawing is the property of H Performance Electric Vehicle Systems Inc. and/or its subsidiaries and affiliates (individually and collectively "HPEVS"), and contains highly proprietary, confidential, and trade secret information of HPEVS. The recipient of this drawing agrees (a) to use the information contained herein for the purpose for which it was furnished by HPEVS (b) to return this drawing upon HPEVS request. This notice shall appear on any complete or partial reproduction of this drawing.

REV	DESCRIPTION	DATE
F	Added wire #49 (Orange/ Black) from R1-2 to reference point B9. Added Splice S9 in Wire#13. The wire after splice S9 to R10-2 was reassigned to wire #51. Added wire #52 (Blue/ White) from Splice S9 to reference point B10.	9/19/2018

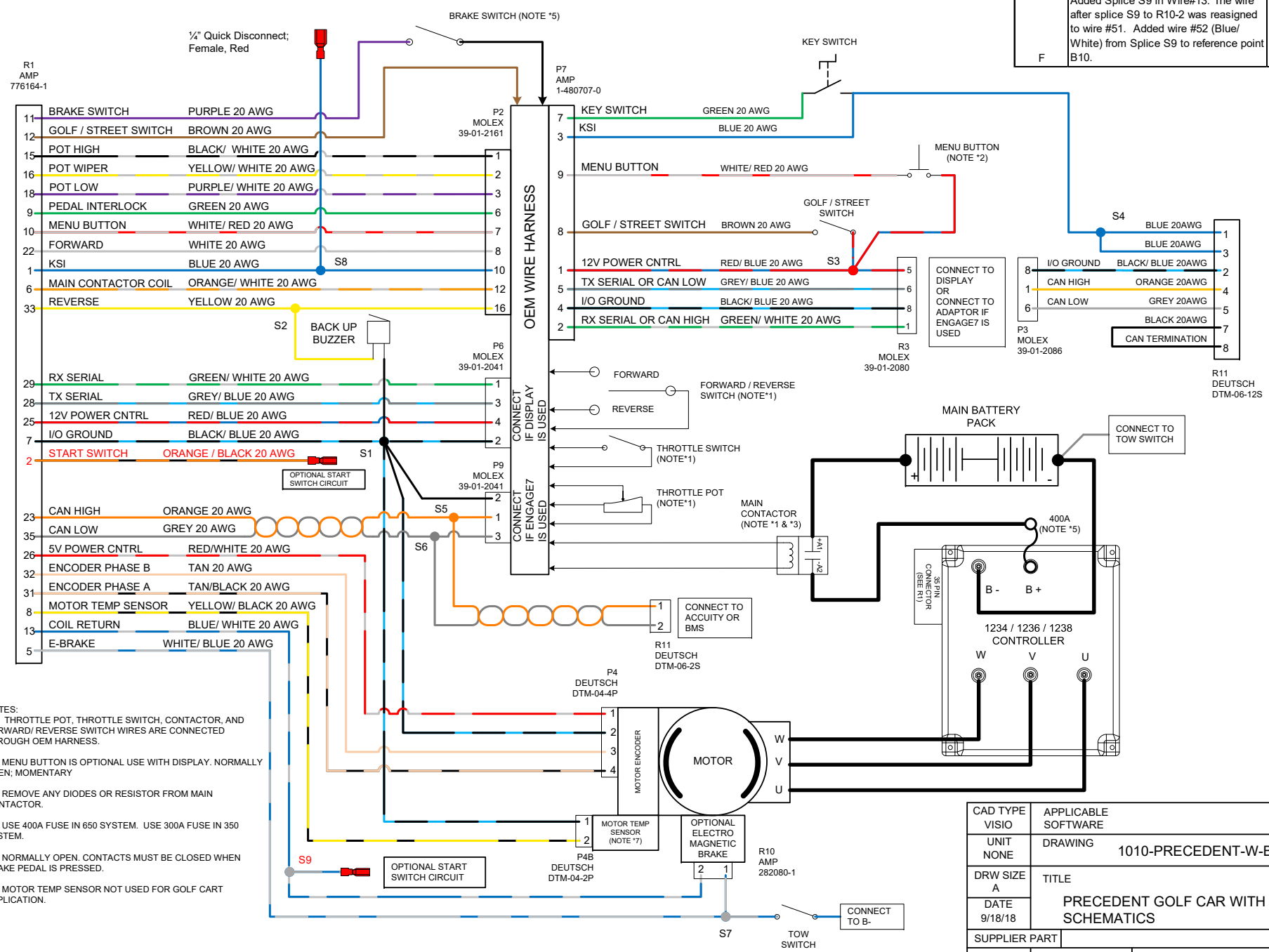

- NOTES:
- (\*1) THROTTLE POT, THROTTLE SWITCH, CONTACTOR, AND FORWARD/ REVERSE SWITCH WIRES ARE CONNECTED THROUGH OEM HARNESS.
  - (\*2) MENU BUTTON IS OPTIONAL USE WITH DISPLAY. NORMALLY OPEN; MOMENTARY
  - (\*3) REMOVE ANY DIODES OR RESISTOR FROM MAIN CONTACTOR.
  - (\*4) USE 400A FUSE IN 650 SYSTEM. USE 300A FUSE IN 350 SYSTEM.
  - (\*5) NORMALLY OPEN. CONTACTS MUST BE CLOSED WHEN BRAKE PEDAL IS PRESSED.
  - (\*6) MOTOR TEMP SENSOR NOT USED FOR GOLF CART APPLICATION.

CAD TYPE	APPLICABLE SOFTWARE
VISIO	
UNIT	DRAWING 1010-PRECEDENT-W-BRAKE
NONE	
DRW SIZE	TITLE
A	PRECEDENT GOLF CAR WITH BRAKE SCHEMATICS
DATE	SUPPLIER PART
9/18/18	
SCALE	SHEET 1 OF 5
1:1	REVISION F HPEVS

# OPTIONAL START SWITCH BUTTON SCHEMATIC

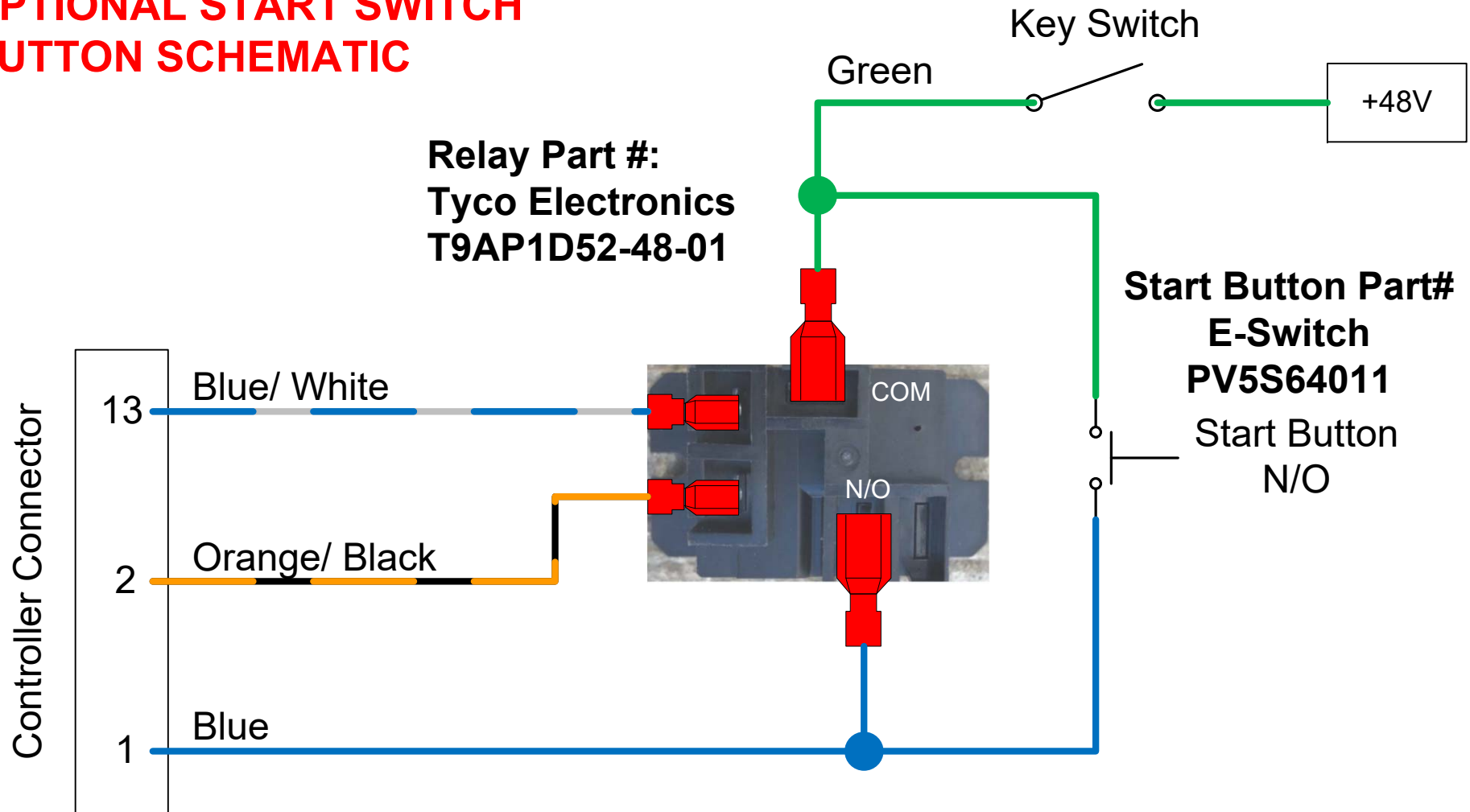

CAD TYPE	APPLICABLE SOFTWARE		
UNIT	DRAWING 1010-Start Switch		
DRW SIZE	TITLE		
DATE	Golf Cart Start Switch		
7/24/18			
SUPPLIER PART			
SCALE	SHEET 1 OF 1	REVISION 1	HPEVS
1:1			