



CURTIS

Manual

enGage[®] VII

CAN Color Instrument



Curtis Instruments, Inc.
200 Kisco Avenue
Mt. Kisco, NY 10549
www.curtisinstruments.com



Read Instructions Carefully!

Specifications are subject to change without notice.

© 2012 Curtis Instruments, Inc. ® Curtis is a registered trademark of Curtis Instruments, Inc.

© The design and appearance of the products depicted herein are the copyright of Curtis Instruments, Inc.

53077 Rev B 5/12

TABLE OF CONTENTS

1.0 Technical Specifications	3
1.1 Electrical.....	3
1.2 Mechanical.....	4
2.0 Installation	6
2.1 Connectors.....	6
2.2 Switch Inputs	12
2.3 Battery Discharge Indicator	13
2.4 CANBus Option	14
2.5 Hour Meter	14
2.6 Maintenance Monitor.....	14
2.7 Odometer	14
2.8 Audible Alarm.....	14
2.9 User Interface.....	15
2.9.1 Configuring Your Panel	15
2.9.2 enGage® VII Menu System.....	15
2.9.3 Choosing Menu System Items.....	19
2.9.4 Exiting Menu System	20
3.0 Environmental Specifications	21
4.0 Trouble-Shooting.....	22
5.0 Maintenance	24
6.0 Safety	24
7.0 Warranty.....	24

1.0 TECHNICAL SPECIFICATIONS

1.1 ELECTRICAL

Power Requirements

The following electrical specifications apply over the operating temperature of -40°C to $+70^{\circ}\text{C}$ unless otherwise noted.

Operating Voltage

enGage® VII models are designed to operate from a nominal B+ voltage range of either 12–48 VDC or 60–144 VDC. B+ operating voltage ranges are given in Table 1.

Table 1

Voltage Rating (VDC)	Minimum Operating Voltage (VDC)	Maximum Operating Voltage (VDC)
12–48	9	60
60–144	45	180

The 12V–48V model incorporates an over-voltage protection circuit which turns off power to the unit in the event of a potentially damaging over-voltage condition. Power is restored when overvoltage condition is removed.

Operating Current

Operating current for B+ input is given in Table 2.



CAUTION: B+ line must be protected by 1A fuse.

Table 2 Operating Current

Model	B+ (VDC)	Typical Operating Current ¹ (mA)	Maximum Operating Current ² (mA)	
		Key switch on	Key switch off	Key switch on
12–48	9	400	417	633
	12	300	293	450
	15	240	234	358
	24	155	150	227
	36	120	96	149
	48	88	86	125
	60	75	68	99
60–144	45	96	80	129
	60	74	63	99
	72	63	51	82
	80	57	48	76
	96	49	43	66
	120	41	35	54
	144	35	30	46
	180	30	26	40

¹ No senders connected; all switches open; 25°C

² Maximum current conditions; senders connected to 0 ohms; switches closed; -40°C to $+70^{\circ}\text{C}$

1.2 MECHANICAL

Display

The enGage® VII features a color TFT quarter-VGA (QVGA) backlit dot matrix LCD, 320x240 pixels. The LCD module has a 5.7" active viewing area, measured diagonally. The display is designed to be viewable in direct sunlight and other high ambient lighting conditions.

LCD Heater B+ Input (Optional)

The enGage® VII features a high performance LCD that operates efficiently down to approx -20°C . If the optional LCD heater circuit was specified at time of purchase, LCD heater B+ input (pin J1-12) is used to power the LCD heater for very low temperature operation.

Pin J1-12 may be wired to B+ to allow the heater to operate whenever power is connected.

Otherwise, the LCD heater may be connected to B+ via the keyswitch to allow the LCD heater to operate only when the keyswitch is turned on.



CAUTION: Voltage at J1-12 must be same as voltage at B+ (J1-1).



CAUTION: Heater B+ line must be protected by 3A fuse.

The LCD heater circuit senses the temperature of the LCD module and turns the heater on and off as needed. The heater turns on at a temperature of approximately -20°C , and turns off at approximately 0°C . The LCD heater circuit uses a PWM circuit to apply constant power to the heater over the range of B+ operating voltages. The average maximum current is given in Table 3 below.

Table 3 LCD Heater Max Avg Values

Voltage Rating (VDC)	Maximum Current (mA)
12–48	2,300
60–144	350

Table 4 Size & Weight (Max)

Item	Fully Enclosed Unit	Module (PCB + LCD only)
	Model 3701T	Model 3701T
Bezel H & W	152 x 190.4 mm	N / A
Case H & W	144.5 x 168 mm	124.5 x 149.1 mm
Depth	71.7 mm (back of bezel to end of connector)	56 mm (top of connector to top of LCD)
Weight	1 Kg	425 grams

Panel Cutout Detail

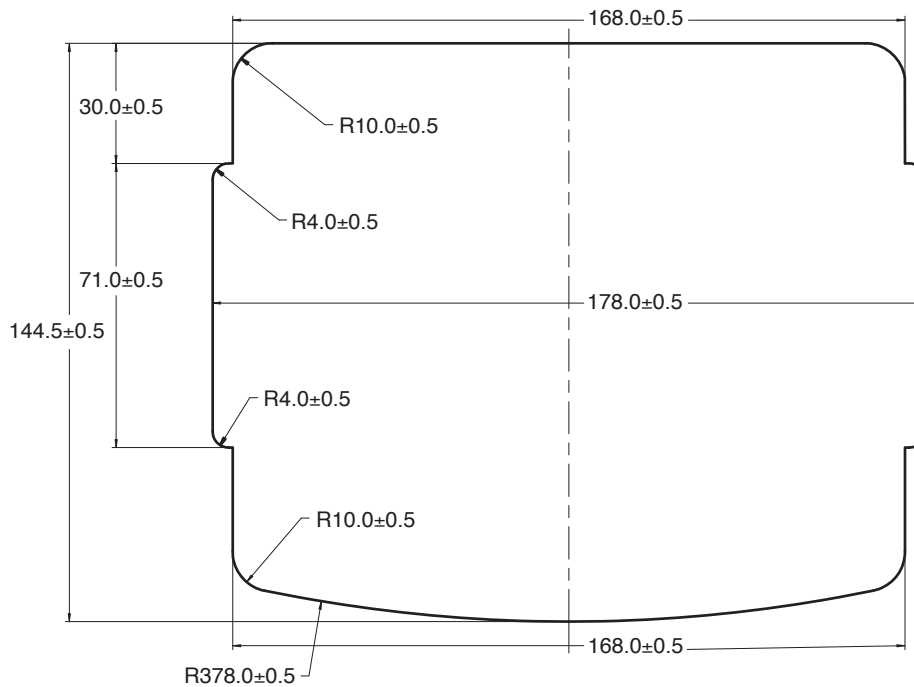

Mounting Options

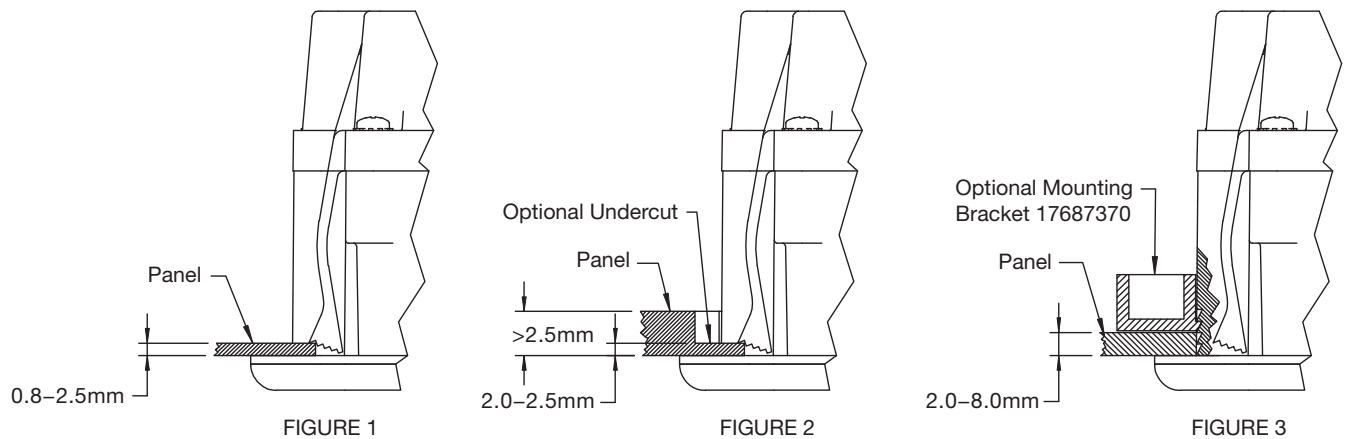

NOTE: Mounting bracket 17687370 can be used for panel thicknesses 2.0–8.0mm. Mounting bracket is designed for one installation only. Destruction of mounting bracket may occur if attempted to remove.

2.0 INSTALLATION

2.1 CONNECTORS

Cased / Enclosed Products (Model 3701T):

- Standard connector series is sealed Deutsch DTM.
- Optional video input is marked “Video In”.

Module Products (Model 3701P):

- Standard connector series is AMP MATE-N-LOK.
- Pushbutton signals are available on connector J4.
- Optional video input uses connector J5 for input signals.

The Curtis enGage® VII is available with extensive I/O & CAN communications or as a CANbus display unit, “CAN only” design (no I/O).

Models designated as “CAN only” do not offer access to I/O pins and have only one connector “J1” (no other connectors required).

I/O connections for module and cased models are detailed in Table 5, on the following page.

Mating Connectors, Cased / Enclosed Product Model 3701T

- Deutsch DTM series mating connectors for J1 through J4 are detailed in Table 6.
- Deutsch Wedge Lock, 1 per connector, part number: WM-12S (Curtis p/n 12690CA29)
- Deutsch pin, up to 12 per connector, part number 0462-201-20141 (Curtis p/n 12690FC59)



CAUTION: Video connector not sealed unless mating connector attached!!

Table 6 Cased / Enclosed Product Model 3701T Deutsch Mating Connector

Connector	Mating Connector	Maximum Operating Voltage (VDC)
	Deutsch p/n	Curtis p/n
J1	DTM06-12SA	12690FH140
J2	DTM06-12SB	12690FH141
J3	DTM06-12SC	12690FH142
J4	DTM06-12SD	12690FH143

NOTE: Housing p/n only, see Page 4 for Wedge Lock and Pin p/n's.

Table 5 Cased / Enclosed Product, Model 3701T Deutsch I/O Connector Signals

Pin No.	Signal Description	Pin No.	Signal Description
J1-1	Battery Voltage (B+)	J2-1	Sender 1
J1-2	Battery Common (B-)	J2-2	No Connect
J1-3	Keyswitch	J2-3	Switch Input 1
J1-4	CAN High	J2-4	Switch Input 2
J1-5	CAN Low	J2-5	Switch Input 3
J1-6	CAN Shield	J2-6	Switch Input 4
J1-7	CAN_Term1	J2-7	No Connect
J1-8	CAN_Term2	J2-8	Backlight Dimmer Input
J1-9	1311 RX	J2-9	Frequency Input 1
J1-10	CAN Common	J2-10	MOSFET Output 1
J1-11	1311 TX	J2-11	MOSFET Output 2
J1-12	LCD Heater B+	J2-12	¹ MOSFET 1 & 2 Common
J3-1	Switch Input 5	J4-1	Switch Input 9
J3-2	Switch Input 6	J4-2	Switch Input 10
J3-3	Switch Input 7	J4-3	Switch Input 11
J3-4	Switch Input 8	J4-4	Switch Input 12
J3-5	Sender 2	J4-5	Switch Input 13
J3-6	No Connect	J4-6	Switch Input 14
J3-7	Sender 3	J4-7	Switch Input 15
J3-8	Frequency Input 2	J4-8	Switch Input 16
J3-9	¹ MOSFET 3 & 4 Common	J4-9	Sender 4
J3-10	Frequency Input 3	J4-10	Potentiometer High
J3-11	MOSFET Output 3	J4-11	Sender 5
J3-12	MOSFET Output 4	J4-12	Potentiometer Low

¹ MOSFET common signals J2-12, J3-9 must be connected to B- externally.

Cased Unit

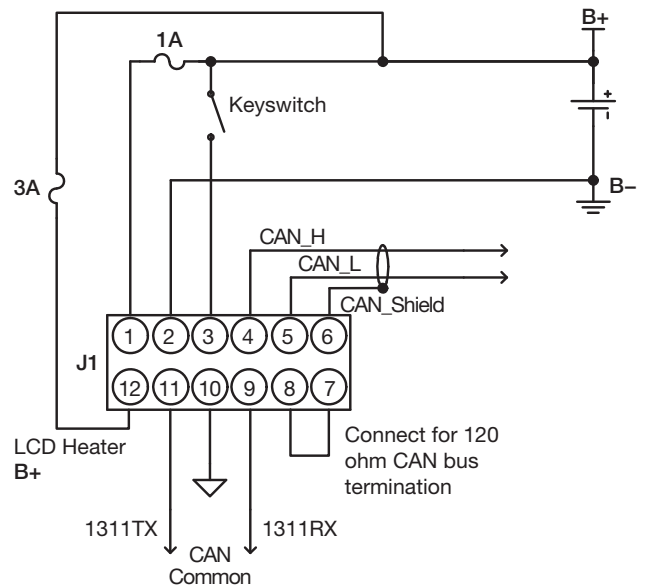
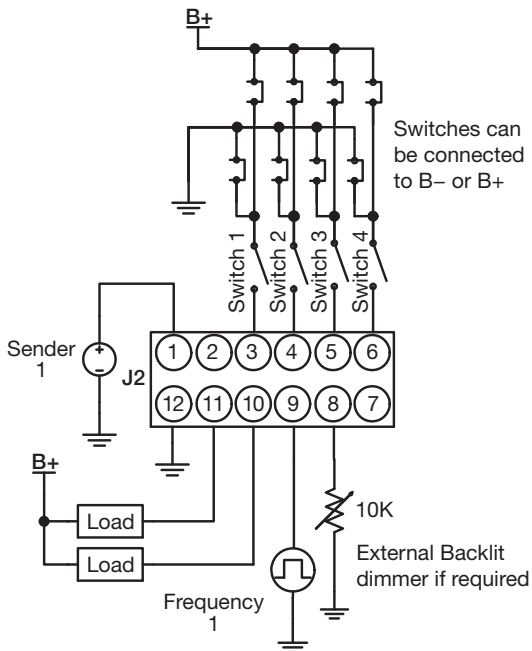
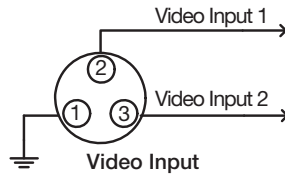
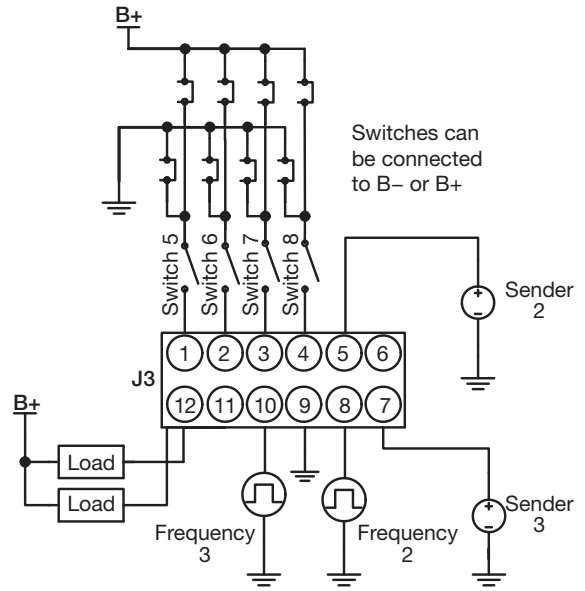
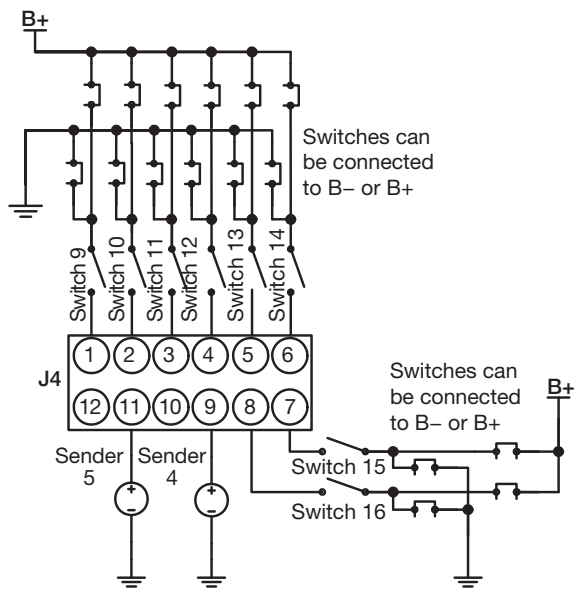

Optional Mating Harness Assemblies (connectors with flying leads and butt splices)

- Connector J1: 15233014-1
- Connector J2: 15233014-2
- Connector J3: 15233014-3
- Connector J4: 15233014-4

Table 7 Module Product, Model 3701P AMP I/O Connector Signals

Pin No.	Signal Description	Pin No.	Signal Description
J1-1	Battery Voltage (B+)	J2-1	Sender 1
J1-2	Battery Common (B-)	J2-2	No Connect
J1-3	Keyswitch	J2-3	Switch Input 1
J1-4	CAN High	J2-4	Switch Input 2
J1-5	CAN Low	J2-5	Switch Input 3
J1-6	CAN Shield	J2-6	Switch Input 4
J1-7	CAN_Term1	J2-7	No Connect
J1-8	CAN_Term2	J2-8	Backlight Dimmer Input
J1-9	1311 RX	J2-9	Frequency Input 1
J1-10	CAN Common	J2-10	MOSFET Output 1
J1-11	1311 TX	J2-11	MOSFET Output 2
J1-12	LCD Heater B+	J2-12	¹ MOSFET 1 & 2 Common
J3-1	¹ MOSFET 3 & 4 Common	J2-13	Switch Input 5
J3-2	Frequency Input 3	J2-14	Switch Input 6
J3-3	MOSFET Output 3	J2-15	Switch Input 7
J3-4	MOSFET Output 4	J2-16	Switch Input 8
J3-5	Switch Input 9	J2-17	Sender 2
J3-6	Switch Input 10	J2-18	No Connect
J3-7	Switch Input 11	J2-19	Sender 3
J3-8	Switch Input 12	J2-20	Frequency Input 2
J3-9	Switch Input 13		
J3-10	Switch Input 14		
J3-11	Switch Input 15		
J3-12	Switch Input 16		
J3-13	Sender 4		
J3-14	Potentiometer High		
J3-15	Sender 5		
J3-16	Potentiometer Low		

¹ MOSFET common signals J2-12, J3-1 must be connected to B- externally.

Table 8 Video Input Connector

Pin No.	Signal Description
1	Video Input Ground
2	Video Input 1 Signal
3	Video Input 2 Signal

AMP Module

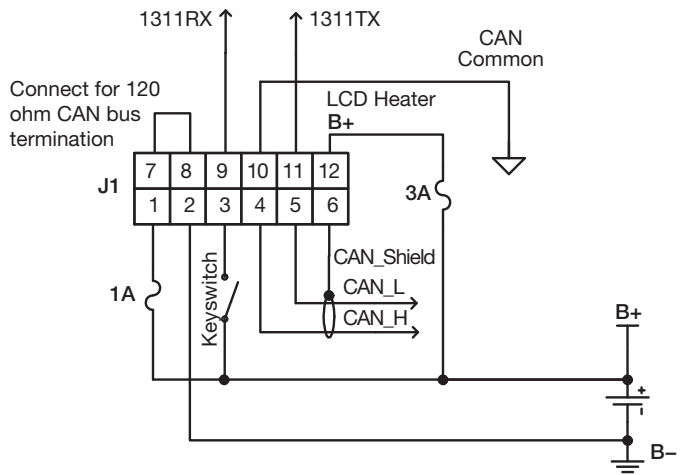
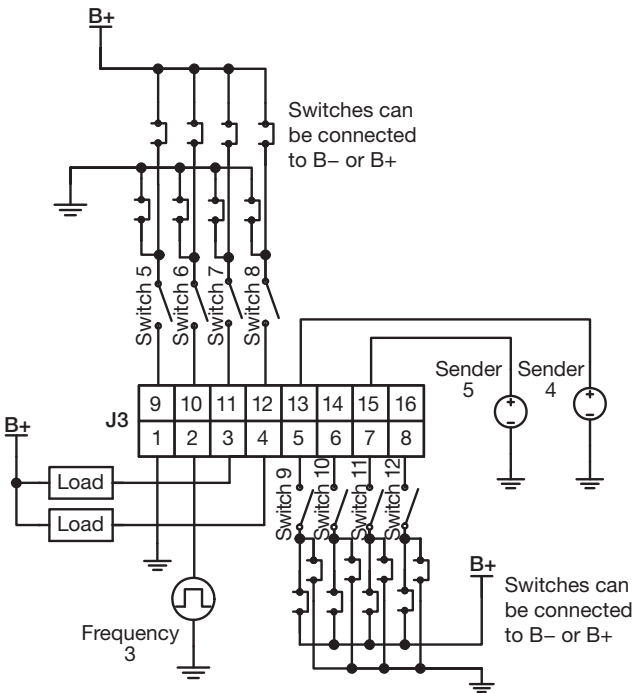
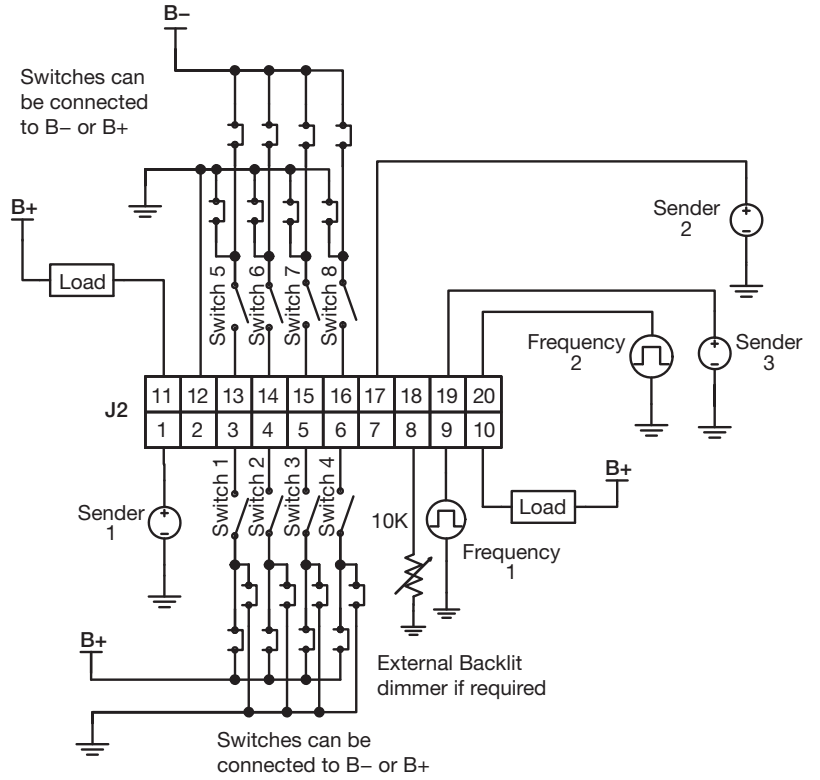
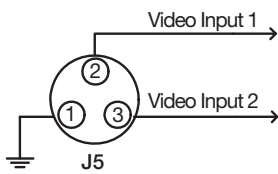
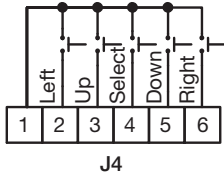

Table 9 Module Product, Model 3701P J4 Pushbutton Connector

Pin No.	Signal Description
1	Common
2	Pushbutton 1 (Left)
3	Pushbutton 2 (Up)
4	Pushbutton 3 (Select)
5	Pushbutton 4 (Down)
6	Pushbutton 5 (Right)

Mating Connectors Module Product, Model 3701P

See Table 10 below for AMP Mini Universal MATE-N-LOK series mating connectors for J1 through J3.

AMP connector pin part number is 770904-1 (Curtis p/n 12690FC36) for use with 18-22 AWG wire.

Table 10 Mating Connector for Module Units, Model 3701P

Connector	Mating Connector	
	¹ AMP p/n	Curtis p/n
J1	770581-1	12690FH81
J2	770585-1	12690FH82
J3	770583-1	12690FH138

¹Housing p/n only, see above for AMP connector pin part number.

Optional Mating Harness Assemblies (connectors with flying leads and butt splices)

- Connector J1: 15233011
- Connector J2: 15233012
- Connector J3: 15233013

Video Connector

Video input mating connector, J5: Binder part number 99-0405-10-03 (Curtis p/n: 12551CM07).

Video Input Option

The optional video input accepts signals from two video sources. It can accept signals in NTSC or PAL format. The video can be displayed in normal or mirrored mode. The unit can be programmed to place the video from either source on the screen when activated. The ◀ pushbutton switches the display to video input 1. The ▲ pushbutton switches the display to video input 2, if two video inputs are enabled. The ▼ pushbutton returns to the main display. The signal to switch to each video display can also be based on one of the switch inputs or on CANbus data. The video image is shown with full resolution and no scaling or zooming.

2.2 SWITCH INPUTS

The switch inputs may be Active-low (switched to B-) or Active-high (switched to B+). The input specifications are given in Table 11 below.

Table 11 Switch Input Specifications

Parameter	Min.	Max.	Units
Input Range	0	180	Volts
Active-High Threshold	8.0	—	Volts
Active-Low Threshold	—	1.0	Volts
Input Impedance	741 k	819 k	Ohms

Keyswitch Input

The keyswitch input meets the same input specifications as the switch inputs (see Table 11). This input is active only when switched to B+.

Backlight Dimmer Control Input

Backlighting is adjustable via the front panel buttons & menu or an optional 10k potentiometer can be connected to J2-8 & B- to externally control the backlight. If an external pot is used for backlight adjustment, backlight adjustment via the menu is disabled.

Sender Inputs

Each sender input can be programmed for either a resistive or voltage based sender. The sender must be referenced to the system ground (B-) connected to the unit. Input requirements and specifications are given in Table 12 below.

Table 12 Sender Input Specifications

Parameter	Min.	Max.	Units
Voltage Input Range	0	180	V DC
Voltage Measurement Range	0	10	V DC
Voltage Resolution	—	10	mV
Voltage Measurement Error	—	+/- (1% + 40 mV)	
Resistance Measurement Range	0	10 k	Ohms
Resistance Resolution (0–1200 Ω)	0.2	5	Ohms
Resistance Resolution (1.2k–10k Ω)	5	35	Ohms
Resistance Measurement Error	—	+/- (3% + 2 Ω)	

Throttle Input

When connecting a throttle to the enGage® VII, the throttle input signal should be connected to Sender 5. The throttle excitation is connected to POT Hi (J4-10 Cased, J3-14 Module). Return for the throttle is POT Lo (J4-12 Cased, J3-16 Module).

The enGage® VII can interface with 2 or 3 wire, 5k Ohm resistive throttles or 0–5V voltage throttles.



CAUTION: It is the responsibility of the OEM to provide full throttle fault protection!

2.3 BATTERY DISCHARGE INDICATOR

The enGage® VII may be configured with a battery discharge indicator (BDI). The BDI function uses the Curtis voltage under load method. The following parameters are needed for accurate BDI tracking:

CTR-Full	Charge Tracking Reset – full voltage
CTR-Empty	Charge Tracking Reset – empty voltage
Discharge-Full	Discharge profile – full voltage
Discharge-Empty	Discharge profile – empty voltage
OCR	Open Circuit Reset voltage
Integration Time	Integration time - charge and discharge
Lockout On	State of charge where lockout is activated
Lockout Off	State of charge where lockout is de-activated

Frequency Inputs

The frequency input pins are used to input signals for a tachometer, speedometer, etc. The input signal is filtered and conditioned, then sent to one of the microcontroller's input-capture timer peripherals. The timer measures the period of the signal's waveform. The default frequency input specifications are given in table 13. Note: additional hardware variations on the PCB may be used for non-standard input signals, in which case the values in Table 13 will vary.

Table 13 Frequency Input Specifications

Parameter	Min.	Max.	Units
Active High Threshold	1.38	—	V DC
Active Low Threshold	—	1.34	V DC
Input Impedance	138.2 k	141.8 k	Ohms
Input Voltage	—	200	V DC
Frequency	1	10 k	Hz
Duty Cycle	10	90	%
Resolution	1	—	µsec
Accuracy	0.5	—	%

MOSFET Outputs

The enGage® VII has four independent open-drain MOSFET outputs. These MOSFET outputs make a connection to their common pin when activated. The MOSFET common pins must be connected to B– externally. Each of the four MOSFET output pins incorporate an inductive spike protection diode connected to B+. **These outputs have no current-limiting circuitry.**

MOSFET output specifications are given in Table 14 below.

Table 14 MOSFET Output Specifications

Parameter	Min.	Max.	Conditions
Continuous Current	0	2 A	
Off Voltage	—	200 V	
On Voltage	0	0.9 V	I = 2A DC

2.4 CANBUS OPTION

CANbus pins CAN TERM 1 & CAN TERM 2 can be connected together to provide a 120 Ohm CANbus termination.

Isolated CANbus Option

The optional isolated CANbus interface allows the enGage® VII to be connected to a CANbus system that is referenced to a separate isolated ground system. The isolated CANbus circuitry has its own power supply and provides galvanic isolation from the rest of the unit's circuitry. The ground for the isolated power supply is connected to J1-10.

The specification for the isolated CANbus option is detailed in Table 15 below.

Table 15 Isolated CANbus Specification

Parameter	Value	Units	Conditions
Dielectric Insulation Voltage	2500	V rms	1 minute duration

2.5 HOUR METER

The enGage® VII keeps track of four hour meters, any of which can be resettable if this option is selected at time of unit purchase. Optional resettable hour meters may be reset via the menu system. Each hour meter may be programmed to accumulate time based on a switched input, keyswitch, CANbus data, etc. More sophisticated logic can be programmed to handle various conditions. Hour meter range is 99,999.9

2.6 MAINTENANCE MONITOR

The enGage® VII keeps track of three count-down maintenance monitors. Each maintenance monitor can be programmed to activate based on a switched input, keyswitch, CANbus data, etc. More sophisticated logic can be programmed to handle various conditions. Each maintenance monitor can be typically reset via the menu system. Maintenance monitor range is 999. Note that maintenance monitors are set using whole number amounts (no decimal point shown). However, once set they will show elapsed time remaining with tenths of an hour resolution.

2.7 ODOMETER

The enGage® VII keeps track of three odometers, any of which can be resettable. The odometer function requires vehicle speed data. This data may come from a frequency input or the CANbus. The units can be displayed as miles or kilometers. The user may switch between miles and kilometers and set the pulses / mile or pulses / km constant via the menu system. Each odometer may be a cumulative type or a "trip" odometer which is resettable. Odometer range is 999,999.9 (units as necessary).

2.8 AUDIBLE ALARM

The enGage® VII includes a PCB mounted audible alarm that has a fixed frequency and volume level of 2,300 Hz, 80 dB respectively. On cased products (model 3701T), sound emits from a vent in the rear of the unit. The alarm can be programmed to activate with one of the switch inputs, CANbus data, when a specified gauge element reaches a certain value, when a sender input reaches a certain value or when an internal calculation reaches a certain value. More sophisticated logic can be programmed to handle various conditions.

2.9 USER INTERFACE

Curtis enGage® VII / enclosed / cased unit (model 3701T) includes 5 front panel buttons*. The buttons are sealed to IP67 and can be used for navigating through a menu system and for programming display functions** such as:

- Time Of Day Clock
- Battery Discharge Indicator
- Maintenance Intervals Set & Reset
- Settable Hour Meters (if applicable)
- Trip Odometer Reset
- Units - Metric / English Conversion
- Backlight Dimmer Control

*For module units (Model 3701P), customer must provide applicable push button interface.

**For complete listing of menu driven adjustable items, see menu diagram later in this manual.

2.9.1 Configuring Your Panel

In order to configure an enGage® VII panel, main power must be applied (12–80VDC or 60–144VDC) to V+ and V– and the keyswitch must be active. Following a power up sequence, the OEM logo (if applicable) will be displayed. Once the start-up process is complete, the specified default (normal) instrumentation screen will appear.

2.9.2 enGage® VII Menu System

The menu system is activated by pressing the center / select button (●) then releasing when the Main Menu screen appears. The following choices will appear on the Main Menu screen:

- OEM Settings
 - » Present if applicable. Six-digit password protected, consult vehicle / system OEM for additional information on password access.
- Maintenance / Service
 - » Present if applicable. Four-digit password protected, consult vehicle / system OEM for additional information on password access.
- User Functions
- Exit Menu

enGage® VII Menu Navigation Flow Chart

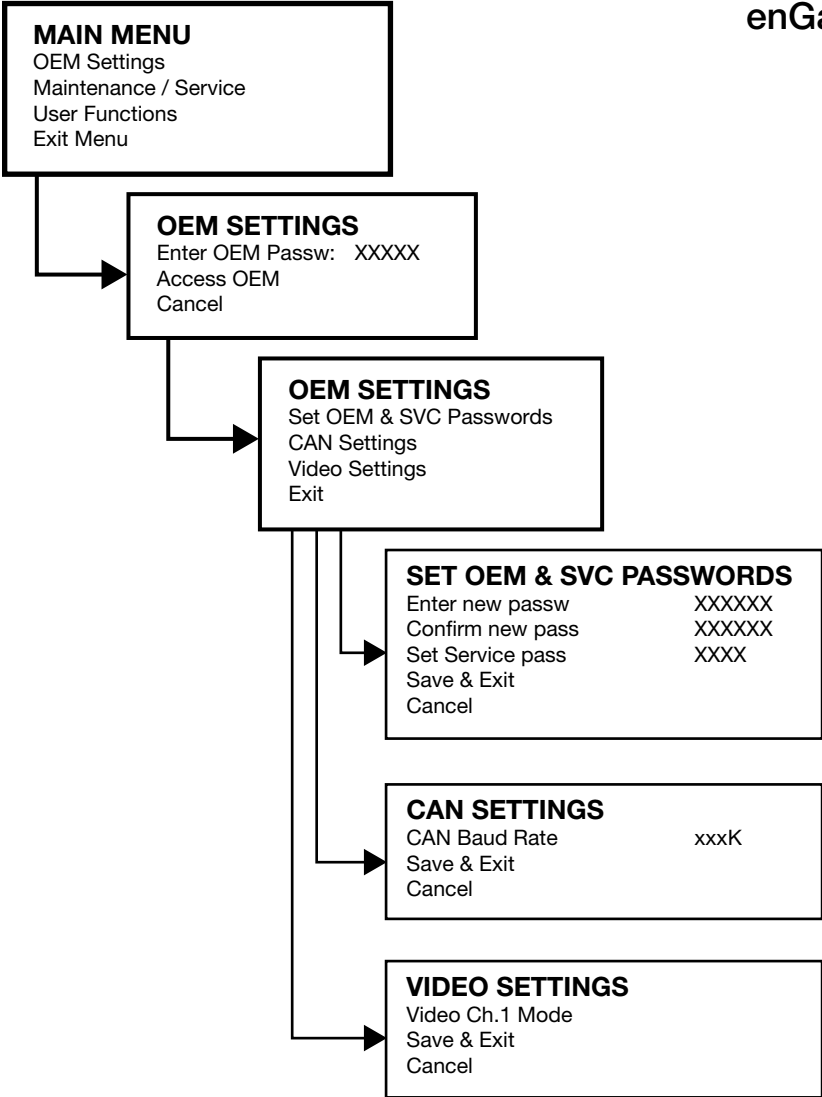

Press ENTER to enter Menu mode.

NOTE:
All Menus exit to their parent menu.
Keyswitch on/off exits the menu.

enGage® VII Menu Navigation Flow Chart

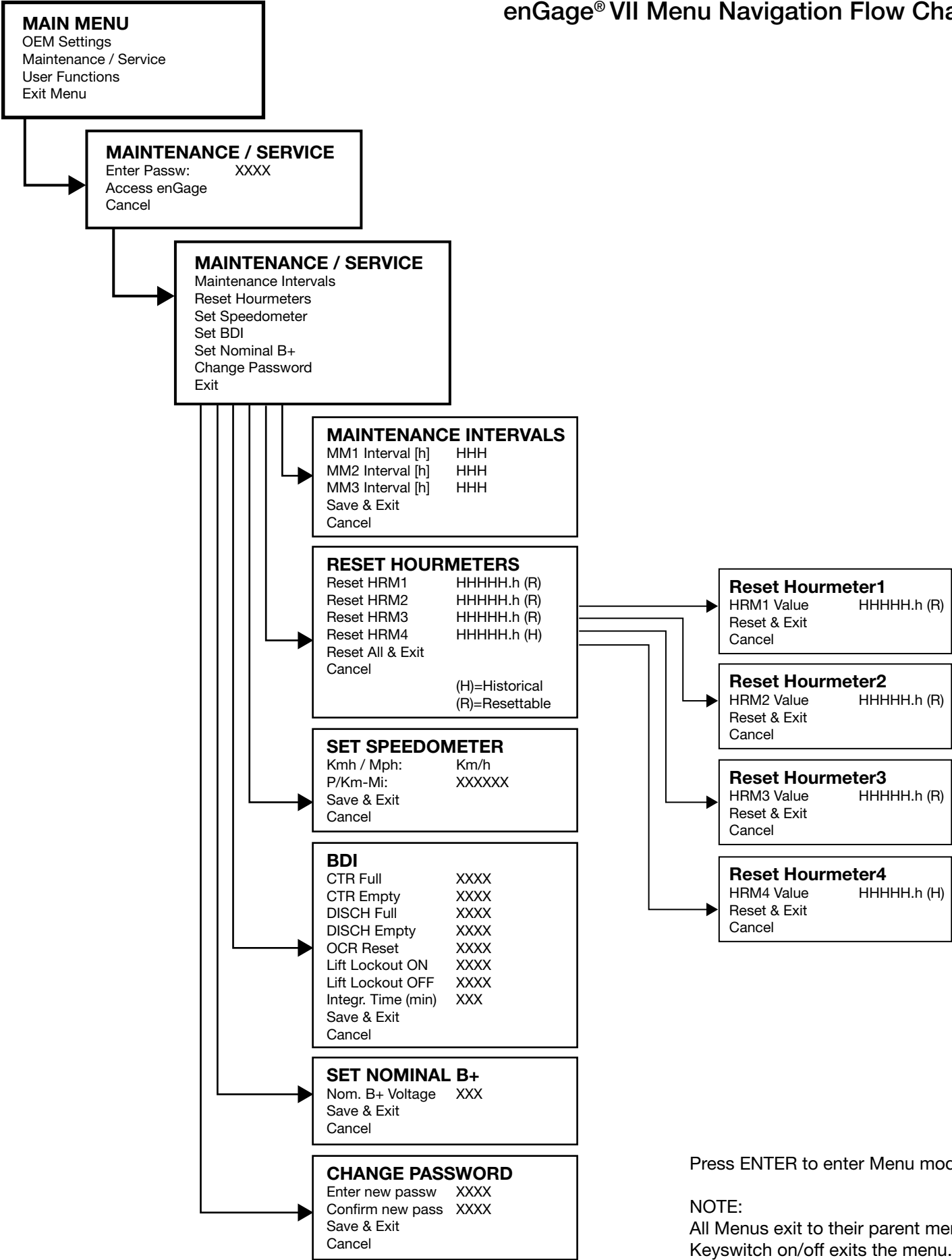

Press ENTER to enter Menu mode.

NOTE:
All Menus exit to their parent menu.
Keyswitch on/off exits the menu.

enGage® VII Menu Navigation Flow Chart

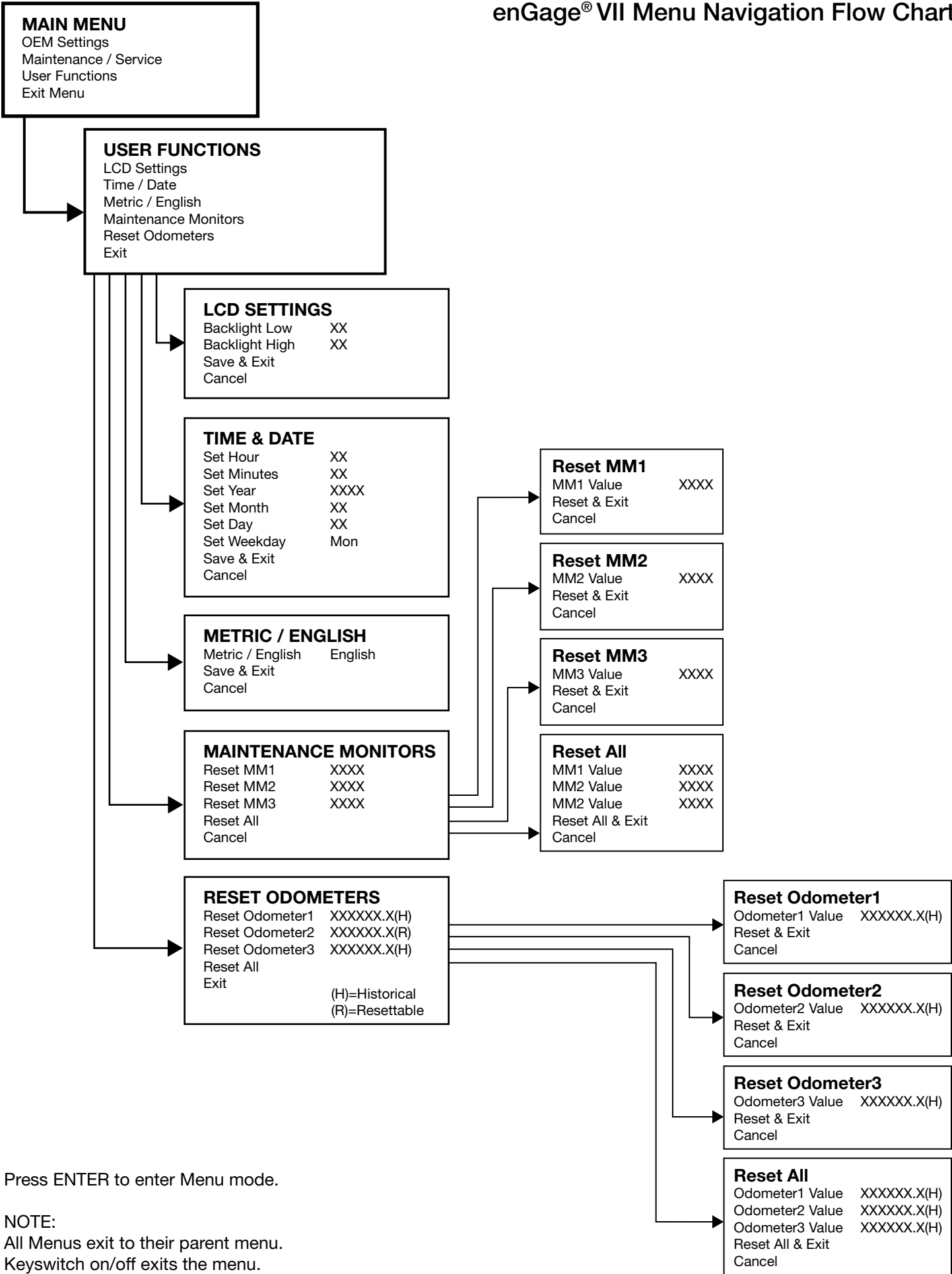

Press ENTER to enter Menu mode.

NOTE:
All Menus exit to their parent menu.
Keyswitch on/off exits the menu.

2.9.3 Choosing Menu System Items

Items are selected within each menu utilizing the up (▲), down (▼) right (▶), left (◀) and center / select buttons (●).

After navigating to the desired menu choice using the arrow buttons, the desired item will be highlighted. Pressing the center / select button (●) chooses the highlighted menu item.

You will then see a new set of choices for the selected item. Depending on your configuration, some menu items may not be present or accessible (consult factory for more details).

Below are select examples for using the menu system to set or re-set various display parameters. All remaining adjustable items are detailed in the menu-tree located on pages 13-15 in this manual.

Maintenance Monitor Reset

Starting from the main menu (you will be in the Main Menu section once you press the center / select button (●) from the standard operating screen), using the up (▲), down (▼), right (▶), left (◀) arrow buttons and center / select button (●) choose “User Functions.” The following choices will appear:

- LCD Settings
- Time / Date
- Metric / English
- Maintenance Monitors
- Reset Odometers
- Exit

Using the up (▲), down (▼), right (▶), left (◀) arrow buttons and center / select button (●) choose “Maintenance Monitors”. Once in the “Maintenance Monitors” menu you will see the following choices:

- Reset MM1
- Reset MM2
- Reset MM3
- Reset All
- Exit

You can now reset the three maintenance monitors. Using the up (▲), down (▼), right (▶), left (◀) arrow buttons and center / select button (●), reset individual Maintenance Monitor channels as desired or all three at once by choosing “Reset All”.

For example, to reset Maintenance Monitor 1, move cursor to choice labeled “Reset MM1” and press center / select button (●). You will then see new menu with the following choices:

- MM1 Value
- Reset & Exit
- Cancel

Utilizing the arrow and select buttons as needed, choose “Reset & Exit”.

You will now be returned to the “Maintenance Monitor” screen detailed above. If you are finished resetting maintenance monitors, using the down arrow (▼) button and center / select button (●) choose “Exit”. You are now returned to the main “User Functions” menu screen.

You can choose to adjust additional user items or return to the “Main Menu” by utilizing the up (▲), down (▼) arrow buttons and center / select button (●) “Exit”.

Setting Metric / English Units

Starting from the main menu screen, choose “User Functions” then “Metric / English”.

Using the right arrow button (▶) move the cursor to the word “English”. You can also change to “Metric” using the up (▲), down (▼) arrow buttons and selecting (●).

Once the desired units are chosen, return to the main menu by pressing the left arrow button (◀) once then down arrow button (▼) to select “Save & Exit”.

Set Clock

Starting from the main menu, choose “User Functions” then choose “Time/Date”. A new list of items will appear:

- Set Hour
- Set Minutes
- Set Year
- Set Month
- Set Day
- Set Weekday
- Save & Exit
- Cancel

Using the up (▲), down (▼), right (▶), left (◀) arrow buttons you can change the desired item. For example, to set “Hour”, using up (▲) or down (▼) arrow buttons highlight “Set Hour”, then press right (▶) arrow button to highlight number. Then press up (▲) or down (▼) arrows to reach desired value. To move on to setting additional items, press left arrow button (◀) once and follow similar procedure for all other items you wish to change.

When finished setting all desired values, choose “Save & Exit”.

2.9.4 Exiting Menu System

From the “Main Menu” screen, using the navigation buttons as outlined above, choose “Exit”. From any other menu screen, keep selecting “Exit” until you arrive at the desired screen.

3.0 ENVIRONMENTAL SPECIFICATIONS

Temperature

Operating:

–40°C to +70°C (see *Note below)

Storage:

–40°C to +85°C

Cycling:

Per SAE J1455 section 4.1.3.1.

Shock:

Per SAE J1455 section 4.1.3.2.

*Note: Deviation from SAE J1455 Aug. 95, section 5.2.1.1 maximum temperature of +85°C due to LCD module limitations.

Humidity

Applicable to enclosed units only: 95% RH (non-condensing) at +38°C as per SAE J1455 Aug. 94, section 4.2.3.

Water / Dust Ingress, IP Rating

Applicable to enclosed units only: sealed front and rear to IP67 with video connector (J5) installed.

Lens Fogging

Applicable to enclosed units only: meets SAE 1810, section 5.6.1.

Lens Scratch Resistance

The standard glass lens is chemically strengthened. The optional polycarbonate lens is hard coated on the outside.

Salt Spray (Fog)

Applicable to enclosed units only: meets SAE 1810, section 5.7.1.1.

Shock

Applicable to enclosed units only: meets SAE 1378 July 98, section 5.6.

Vibration

Applicable to enclosed units only: Meets SAE J 1378 July 98, section 5.5.

EMC Specifications

Emissions

Designed to meet the following:

- EN 61000-6-4:2007

EMC Specifications continued

Immunity

Designed to meet the following:

- SAE J1455 section 4.11.2.2.1 & 4.11.2.2.2
- EN 61000-6-2:2005, EN 61000-4-2:2009
- EN 61000-4-3:2006, EN 61000-4-4:2004, EN 61000-4-5:2006
- EN 61000-6-4:2007

Safety

Meets EN 61010-1:2010 Part 1 - General safety requirements for measurement, control and laboratory use.

Regulatory Approvals

CE Mark

Designed to meet the Low Voltage Directive (LVD) 2006/95/EC and EMC Directive 2004/108/EC.

UL Mark

Product specification will be updated upon completion of testing.

4.0 TROUBLE-SHOOTING

GENERAL

Problem / Possible Cause

No Display –

V+ (keyswitch) voltage not present at J1-1, J1-3.

Battery voltage too low. Battery terminals not connected.

Display Too Dark/Light –

LCD backlight not adjusted correctly.

BDI FUNCTION

Problem / Possible Cause

No Display –

Terminals not connected.

Improper voltage – Check B+ / B- is connected to proper pins (see tables earlier in this manual).

Stays At FULL –

Instrument voltage range selected does not match battery voltage.

V+ connected to wrong terminal.

BDI information coming from CAN network, CAN network value not correct.

Will Not Reset –

Instrument voltage does not match battery voltage.

Battery not fully charged, battery may be defective.

BDI information coming from CAN network, CAN network value not correct.

Resets Without Charging Battery –

Not connected directly to battery terminals.

Empty Too Soon –

Range Select V+ connected to wrong terminal.

Instrument voltage does not match battery voltage.

Terminals not connected directly to battery.

REAL TIME CLOCK (RTC)

Problem / Possible Cause**Correct Time, Date Not Saved When Main System Power (Battery) Disconnected –**

Internal battery depleted. Note that internal RTC battery life rated for 10 years minimum.

Correct Time, Date Not Shown On Main Display –

Time, date not set correctly per RTC time, date set section of manual.

SENDER FUNCTION

Problem / Possible Cause**No Display –**

Improper voltage – Check B+ / B- is connected to proper pins (see tables earlier in this manual)

Stays At Maximum/Minimum –

Sender or sender connection issues.

Sender connected to wrong terminal.

Incorrect sender used.

MAINTENANCE FUNCTION

Problem / Possible Cause**Will Not Reset –**

Procedure as described in earlier section not being followed.

5.0 MAINTENANCE

The enGage® VII is not field serviceable.



CAUTION: The protection provided by enGage VII may be impaired if the device is used in a manner not specified by Curtis Instruments, Inc.

6.0 SAFETY

SAFETY

This instrument was manufactured and tested according to the applicable technical standards. It complies with all the safety regulations as shipped from the factory.

Installation and startup must be performed by skilled personnel.

Failure to install and operate the unit in accordance with these instructions may result in damage or injury.

If safe operation of the instrument can no longer be ensured, stop and secure it against accidental operation.

If instrument failure or malfunction may cause personal injury or material damage, use additional safety measures such as limit switches, guards, etc.

Read Operating Instructions carefully before startup.

Note the safety instructions marked with this warning symbol in this manual.

7.0 WARRANTY

Two year limited warranty from time of delivery.